

WARING COMMERCIAL TORq 2.0 Blender Variable Speed Control TBB175

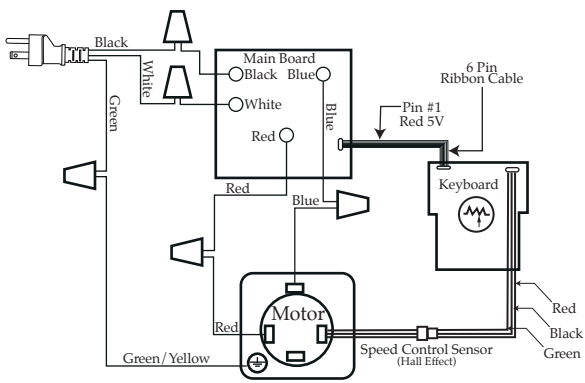

Wiring Diagram

Unit Information

120 volts – 60 Hz – 13 Amp
 Variable Speed From 1,000 to 17,000 Rpm's
 48 oz. Stackable Break Resistant Container
 Limited 2 Year Motor Warranty & 1 Year
 Parts and Labor

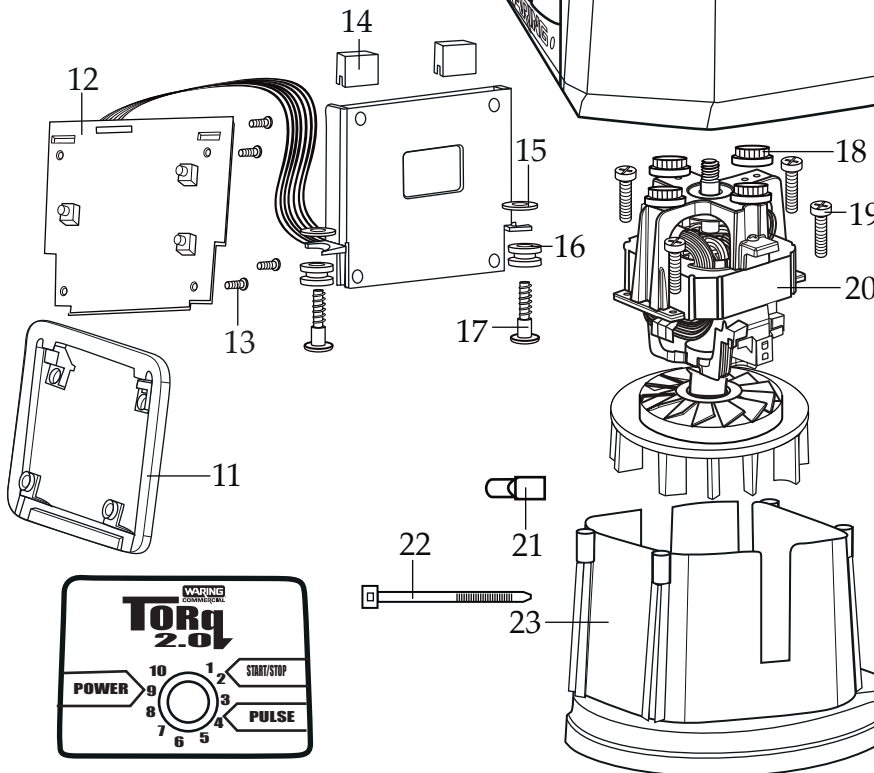
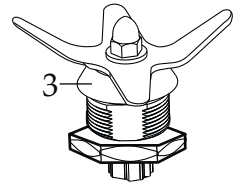
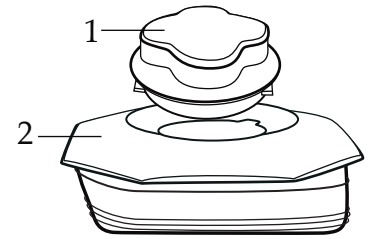
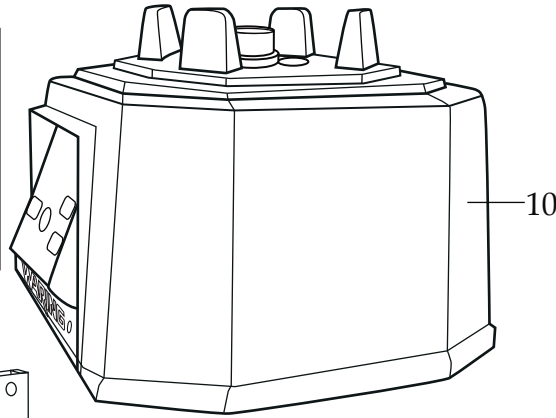
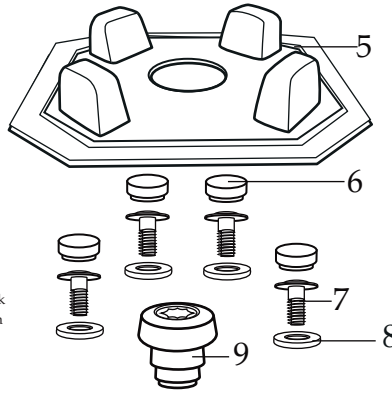

013304
NSF Seal

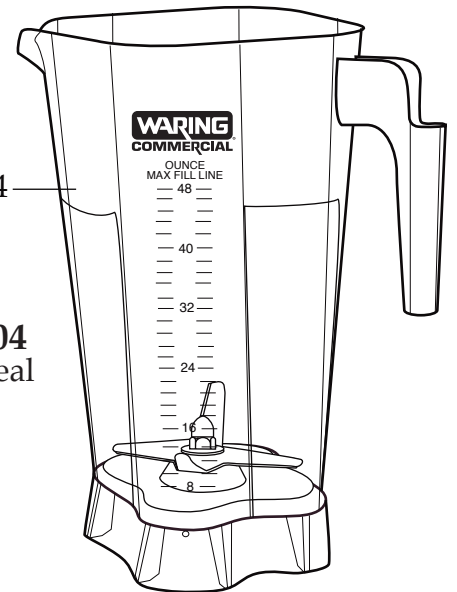

503482

Container with Blending Assembly

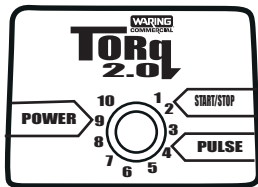

035299

Control Panel Overlay

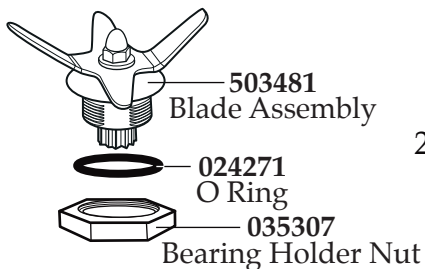

035465

Blending Assembly

(with O ring and bearing holder nut)

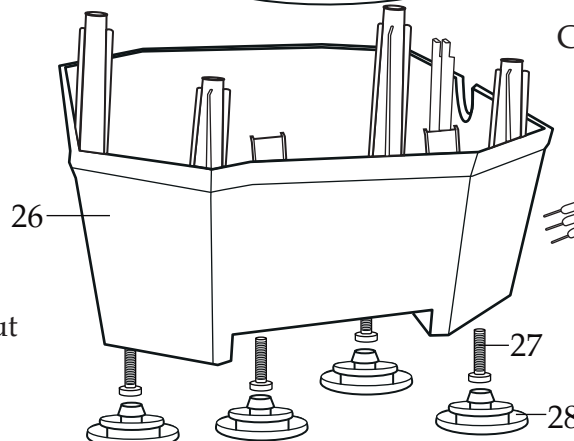

Illustration #	Part #	Description
1	028769-E	Eastman Jar Lid Cover
2	035238-V	Vinyl Jar Lid
3	035465	Blending Assembly (with O ring and bearing holder nut)
4	035239	48 oz. Stackable Container ONLY
5	035091	Jar Pad
6	030859	Hole Plug (4 required)
7	034275	Shoulder Screw (4 required)
8	034273	B Gasket (4 required)
9	035251	Drive Coupling
10	503460-175	Top Housing Assembly
11	034899-09	Black Control Housing Back
12	034905	TBB175 Control Panel Assembly
13	034903	Screw (4 required)
14	034900	PCB Cushion (2 required)
15	013604	Washer (2 required)
16	034904	Rubber Pad (2 required)
17	034902	Shoulder Screw (2 required)
18	034272	A Gasket (4 required)
19	034274	Screw (4 required)
20	034276	Motor
21	012409	Small Crimp Connectors (5 required)
22	013731	Cable Ties (2 required)
23	503483	Motor Housing with Dampeners
24	035124	Cordset
25	007556	Strain Relief
26	035079	Bottom Housing
27	034274	Screw (4 required)
28	035088	Foot (4 required)