

Unit Information

120 volts – 60 Hz – 2.8 Amps
180 Watts

Unit Dimensions:
L 16.7" x W 12.2" x H 10.3"
Removable Bowl Hand Wash

Sanitize all parts that will come into contact with ice cream Before First Use. Sanitizing instructions in manual.

WARING COMMERCIAL®

2 Qt. Compressor Ice Cream Maker WCIC20

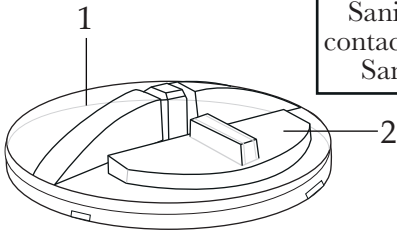

035755

2 Piece Lid (WCIC20LID)

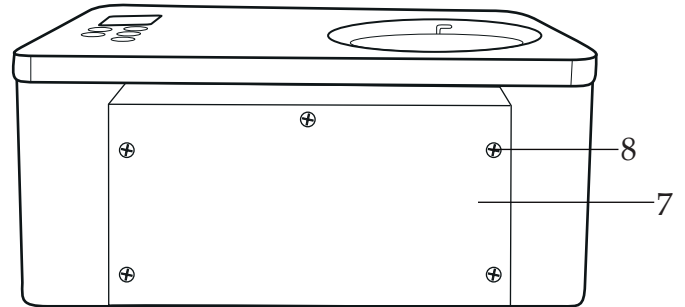
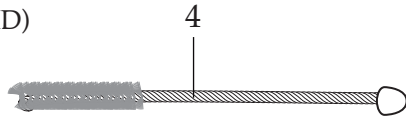

Back View

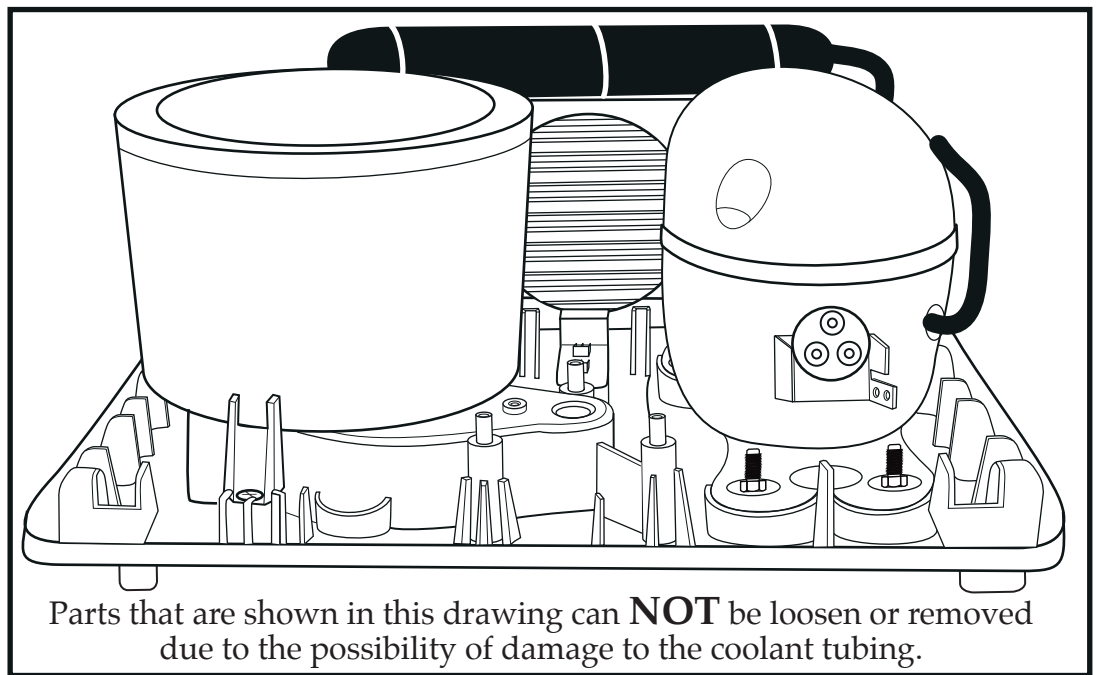
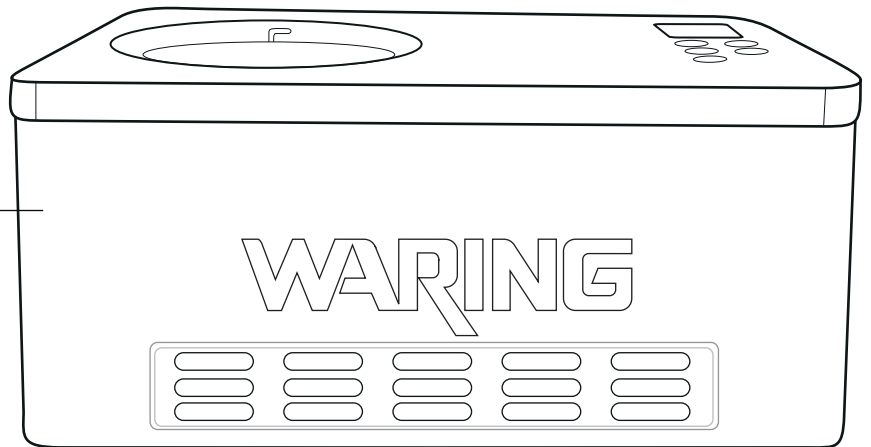
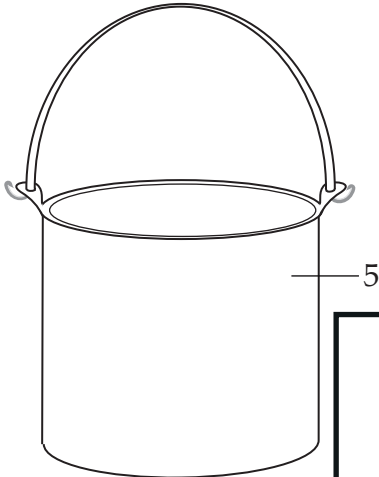
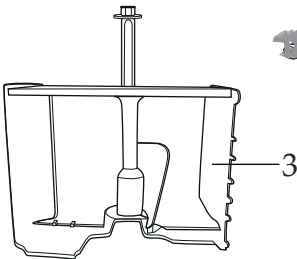

WARING COMMERCIAL[®]

2 Qt. Compressor Ice Cream Maker WCIC20 Base Unit Assembly

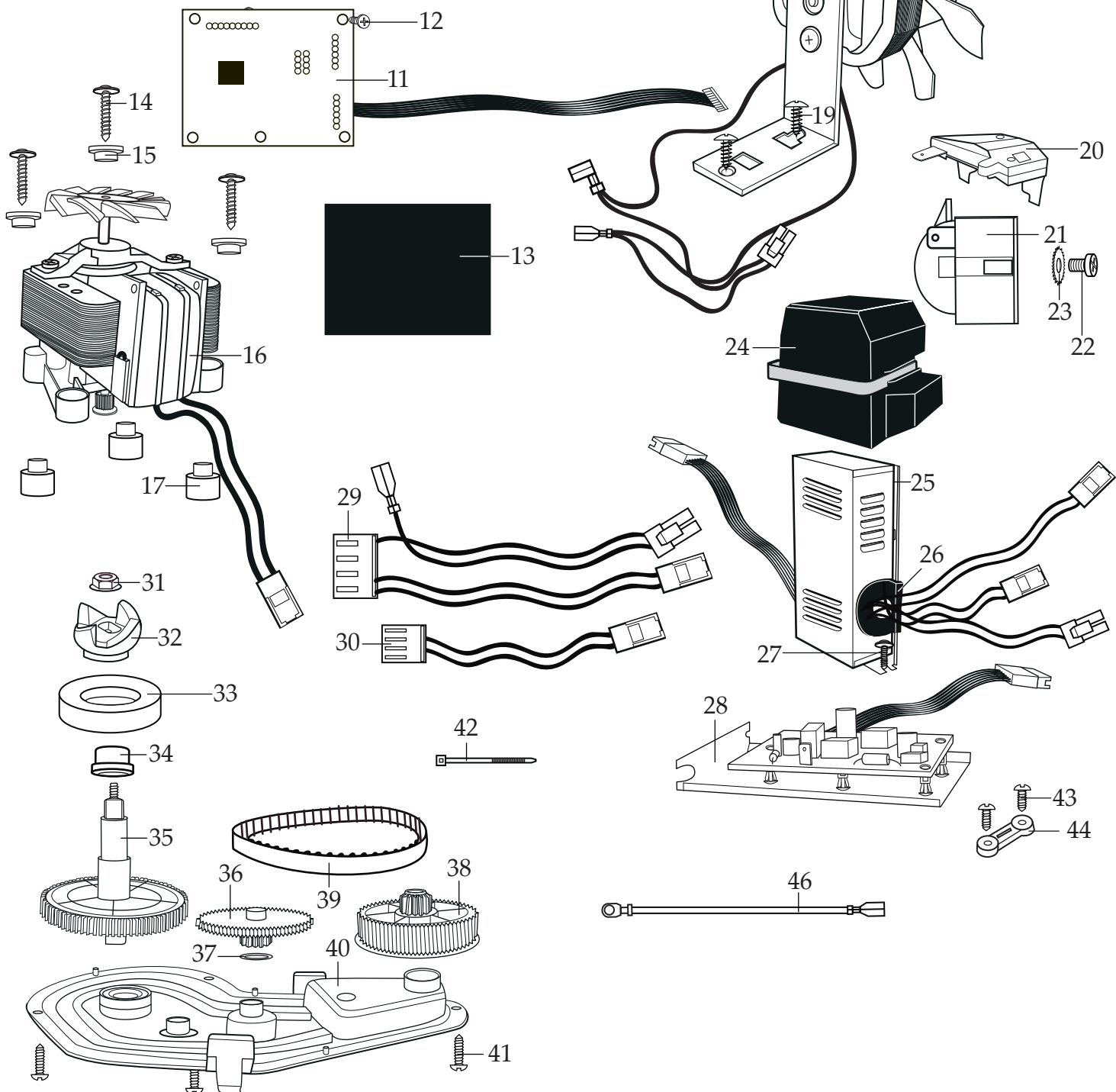
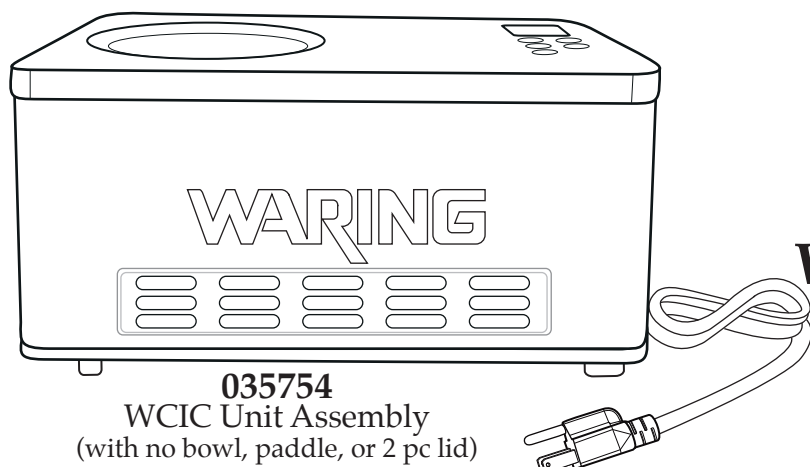



Illustration #	Part #	Description
1	035712	Batch Bowl Lid
2	035713	Mix Ingredient Lid
3	035714	Mixing Paddle
4	035715	Brush
5	035716	Removable Bowl
6	035717	Top Housing Assembly
7	035718	Back Cover Plate
8	035719	Back Cover Plate Screw (5 required)
9	035720	Base Plate Assembly Screw (10 required)
10	035721	Foot (2 required)
11	035722	PCB Control with Lead Tape
12	035723	PCB Control Screw (4 required)
13	035724	Rubber Stickey Sheet
14	035725	Mixing Motor Screw (3 required)
15	035726	Small Rubber Motor Mounts (3 required)
16	035727	Mixing Motor Assembly
17	035728	Large Rubber Motor Mounts (3 required)
18	035729	Fan Motor with Bracket Assembly
19	035720	Fan Motor Screw (2 required)
20	035730	Single Pole Terminal
21	035731	Double Pole Terminal
22	035732	Ground Screw (2 required)
23	035733	Ground Lock Washer (2 required)
24	035734	Pole Terminal Cover
25	035735	Power Supply Assembly Complete
26	035736	Rubber Wiring Tube (2 required)
27	035737	Power Supply Assembly Mounting Screw
28	035738	Power Supply Board Assembly with Plate



Illustration #	Part #	Description
29	035739	Red-Blue Double Power Board Lead Harness Assembly
30	035740	Red-Blue Single Power Board Lead Harness Assembly
31	035741	Nut
32	035742	Nether Clutch
33	035743	Seal
34	035744	Bearing
35	035745	Cylinder B Gear Assembly
36	035746	Cylinder A Gear
37	035747	Nylon Washer (2 required)
38	035748	Big Gear
39	035749	Drive Belt
40	035750	Base Gear Cover
41	035723	Base Gear Cover Screw (3 required)
42	013731	Wire Tie (10 required)
43	035723	Cord Clamp Screw (2 required)
44	035751	Cord Clamp
45	035752	Cord with Lead Assembly
46	035753	Green/Yellow Ground Lead